

CAD FILE:

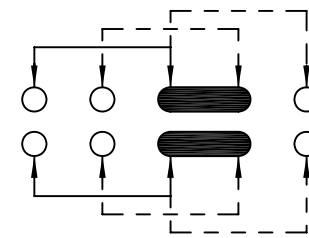

SCHMATIC (SHORTING)

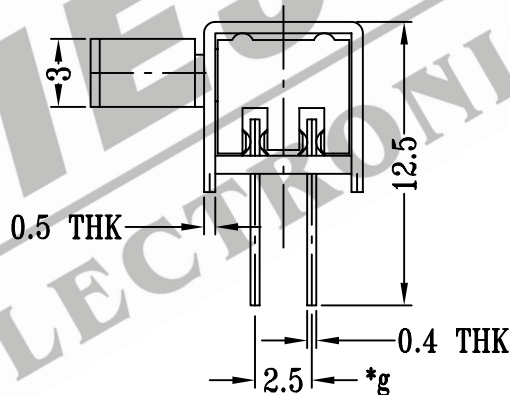
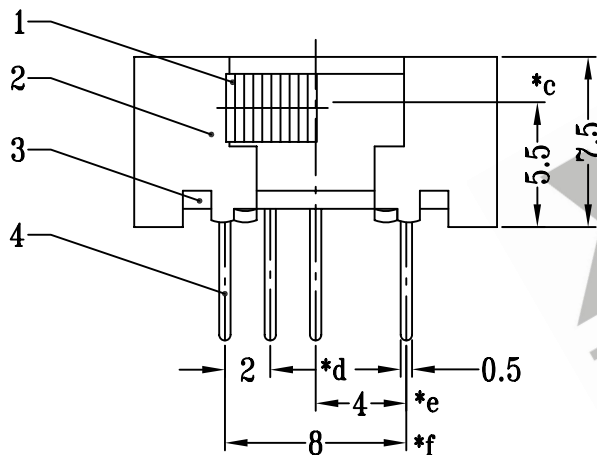
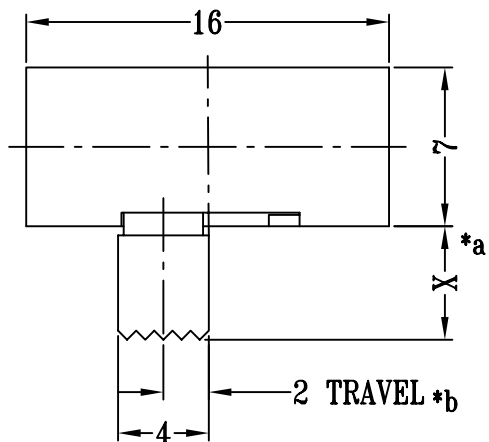
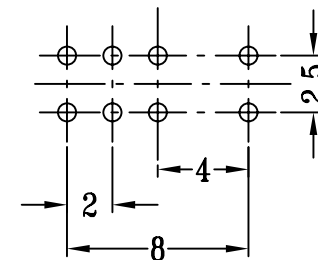

P.C.B LAYOUT

注:带"*"表示关键尺寸(7个)

8					TOLERANCE UNLESS SPECIFIED	SHENZHEN XIEJIA ELECTRONICS CO.,LTD.				
7	CONTACT CLIP	PBS STRIP	2	Ag PLATED	WITHIN: 1.5±0.1mm	ISSUE	DATE	DESCRIPTIONS		APPD.
6	SPRING	STEEL WIRE	1	TEMPER	OVER : 1.5±0.2mm					
5	STEEL BALL	STEEL	1	NATURAL	TITLE : HORIZONTAL SLIDE SWITCH	UNIT : MM	DRWG NO.: XJ-DR-SK23D24-00			
4	TERMINAL	BRASS STRIP	8	Ag PLATED OVER Ni PLATED			MODEL: SK-23D24	SCALE: 3:1	DWN.	ZHOUYU
3	BASE	PHENOLIC RESIN	1	NATURAL	ALL MATERIALS MUST BE COMPLIANT TO ROHS				CHK'D	FANGYING
2	FRAME	STEEL STRIP	1	Ni PLATED			APPD.		KANGXINAN	2001-6-26
1	KNOB	POM	1	BLACK						
NO.	PART NAME	MATERIAL	Q'TY	FINISHING						